

## **From A to A+** **IEEE 802.3at PoE+ White paper**

Enhanced High-End Critical Surveillance  
Networks through the Revolutionary  
Industrialized High Power IEEE 802.3at PoE  
Technologies!



## **Preface**

PoE technology has become commonplace when building networks for providing security, safety and process monitoring in industrial facilities. By connecting and powering devices using a common network infrastructure, the PoE-enabled device provides total cost savings on power source installation and future maintenance, power reliability and simplified remote device management.

Today, with the complexity of networks and the increase of feature-rich devices in industrial automation, such as video phones and multiradio access points, the PoE Plus promises to deliver even more power to enable a new breed of Ethernet devices.

This document briefs PoE technology and provides an overview of the advantages of High Power PoE, discusses the concerns for practical PoE deployment in industrial environments and highlights Korenix, the World's 1st technological advances reflected in JetPoE and JetBox series.

# Glossary of Terms

## Summary

<b>Chapter 1. PoE Introduction and Advantages</b> .....	3
<b>1.1. What is PoE</b> .....	3
- History and Standardization	
<b>1.2. How it Works</b> .....	3
- PoE System Architecture	
- Process Flow of PoE	
<b>1.3. How PoE Benefits You</b> .....	6
<b>Chapter 2. Getting More Power: From A to A+</b> .....	8
<b>2.1. PoE+ Market Growth</b> .....	8
<b>2.2. PoE vs PoE+: Technology Differences</b> .....	8
- Cabling, current, voltage and wattage	
- Classification	
<b>2.3. PoE+ Advantages over PoE</b> .....	10
- High Power Capacity	
- Powering on Demand	
- PoE and PoE+ Quick Comparison	
<b>Chapter 3. PoE Challenges for Industrialized Applications</b> .....	12
<b>3.1. Industrial PoE Application Markets</b> .....	12
- Bus Surveillance	
- Urban Security and Communication	
- Subway Monitoring	
- Airport Security and Surveillance	
<b>3.2. Industrial PoE Challenges</b> .....	16
- Hazardous Operating Environment	
- Diverse Power Demand	
- Power Control	
- Network Management and Reliability	
- Computing and Remote Control	
<b>Chapter 4. Leading Industrial PoE Solutions: Going Beyond A+</b> .....	19
<b>4.1. Pioneer Industrial PoE Technologies</b> .....	20
- Critical Power Delivery via Pioneer High Power and Booster PoE technologies	
- Reliable & Economic Powering via Intelligent PoE Power Management Technologies	
- Outstanding Industrial-grade Design through Leading-Edge Ruggedization Technologies	
- Exclusive Board-Level PoE Solution for Embedded System	
- Enhanced Network Management and Security for High-Quality Networking	
- All-in-One Smart Computing and Routing Solution for System Extension & Easy Remote Control	
<b>4.2. JetPoE Series Switches Quick Selection Guide</b> .....	28
<b>4.3. JetBox Series Computers Quick Selection Guide</b> .....	32
<b>Summary</b> .....	34
<b>Glossary</b> .....	35

# Chapter 1. PoE Introduction and Advantages

## 1.1. What is PoE

PoE is an evolving technology designed to simultaneously provide power and data connectivity over existing Ethernet cable, eliminating the need for running separate and expensive power cables, AC electrical outlets, etc. By removing the power cords and the power infrastructure, this technology greatly simplifies the wiring and deployment matters and brings lots of convenience and benefits in home, office and industrial environments.

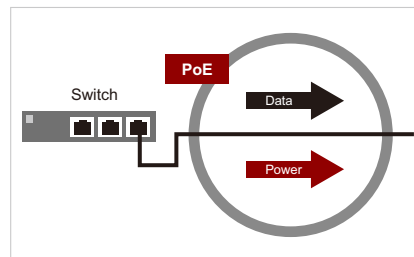

### History and Standardization

To integrate running power over the structured cabling system, industry standards have been created. In 2003, the Institute of Electrical and Electronics Engineers (IEEE) has approved 802.3af standard defining the PoE technology. However, with recent technological developments

modern powered devices require power greater than the allowable 15.4W specified in IEEE 802.3af, which has lead IEEE board to ratify new 802.3at High Power PoE standard in 2009 (IEEE 802.3at standard and its advantages will be discussed in Chapter 2).

## 1.2. How it Works

### PoE System Architecture

A typical PoE installation involves three major components (see Figure 1):

- **Power Sourcing Equipment (PSE)** such as Ethernet switch, which provides power and data,
- **Powered Device (PD)** such as IP phones, access points, network cameras, which receive power,
- **Ethernet Cable (standard CAT. 5)** through which data is transferred.

Normally, the power applied by PoE is 48V with a maximum current of 350mA which would supply 15.4W power to drive a variety of devices, such as wireless APs, IP security cameras and so on.

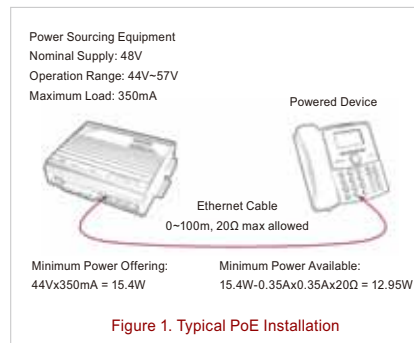

Figure 1. Typical PoE Installation

## 1. Cabling

The standard CAT. 5 Ethernet cable used for connecting PSEs and PDs has four twisted pairs (UTP). However, only two of them are used for 10BASE-T and 100BASE-TX data transmission. To integrate power and data over the cable,

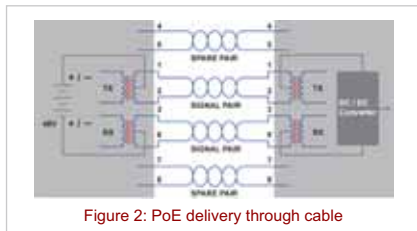

Figure 2: PoE delivery through cable

### Alternative A:

Also known as phantom powering, a PSE feeds power along the data pairs on pin 1/2 and 3/6 without disturbing data transfer.

According to the standard, PSE can be designed to apply power by alternative A or alternative B, but not both at the same time. As a result, a powered device (PD) must be capable of receiving power from both options while the source (PSE) may apply power in either way.

IEEE802.3af defines two options for different circumstances.

Below images illustrate the two options, which are referred to as alternative A and B.

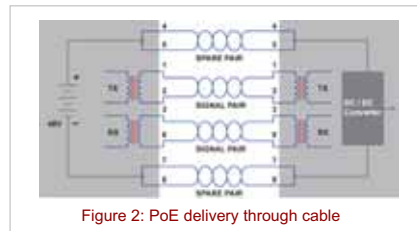

Figure 2: PoE delivery through cable

### Alternative B:

The power is delivered through the idle pairs; pin 4/5 form the positive supply and pin 7/8 form negative supply.

## 2. Power Sourcing Equipment

Power Sourcing Equipment (PSE) is a device that supplies power to the powered device. A PoE capable switch is a most common example of PSE. Acting as a power transmitter, the PSE has three main jobs:

- detect a PD and determine the PD's power level
- supply adequate power according to the power level
- monitor and stop power supply

2 basic types of PSE are specified by IEEE 802.3af PoE standard: Endspan and Midspan.

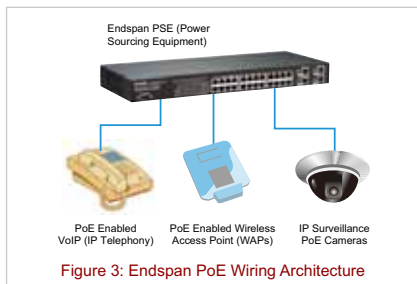

Figure 3: Endspan PoE Wiring Architecture

An Endspan PSE is a PoE capable port that carries both data and power on the link, while a Midspan PSE stands between a common

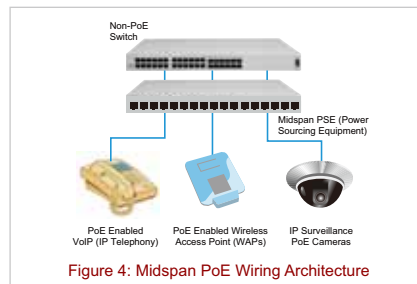

Figure 4: Midspan PoE Wiring Architecture

Ethernet port and a PSE injector to help injecting power without affecting the data.

In this document we will focus on presenting different technological enhancements as well as the advantages of using Endspan PSE equipment in industrial-grade deployments.

### 3. Powered Device

Powered Device (PD) (see Figure 5) is a device that receives power from PSE. More and more network attachments today, such as IP phones, wireless LAN access points and IP cameras are designed as a PD.

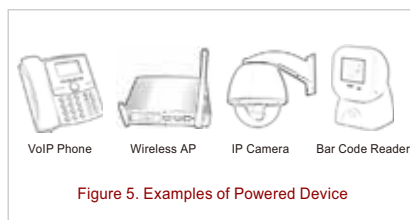

Figure 5. Examples of Powered Device

## Process Flow of PoE

Fundamentally, a PD must fulfill four functions in order to act in conjunction with the sending end PSE. The functions are Detection, Classification, Power Forwarding and Disconnection.

### 1. Detection

PSE tests for a connection to see if a PD is connected. To do so, it applies 2 small current-limited DC volts across the cable and measures the impedance to determine whether a valid PD is present (it has to contain 19kOhm~26.5kOhm signature resistor).

When a PD is detected, 15.5~20.5 volts power will be applied. To read the power level of the PD, the PSE should further enter the 2nd phase, Classification.

### 2. Classification

The PSE tries to classify a PD into classes by presenting another voltage on the connection. Following the process, the PD makes a response with a load current corresponding to its classification. The PSE can then identify the power requirement of PD and optimize its power supply.

Class	Usage	Maximum Power Levels Output at the PSE	Maximum Power Levels at the Powered Device
0	Default	15.4W	0.44 to 12.95W
1	Optional	4.0W	0.44 to 3.84W
2	Optional	7.0W	3.84 to 6.49W
3	Optional	15.4W	6.49 to 12.95W

Table 1: Power Ranges and PD Classes

Table 1 details the class and corresponding power level delivered from PSE and received at PD. As can be seen, Class 0 is the default setting. IEEE802.3af provides 4 classes (0 to 3) which translate into three PSE power allocation values: 4.0 Watts, 7.0 Watts or 15.4 Watts.

Figure 6: Process Flow of PoE Procedures

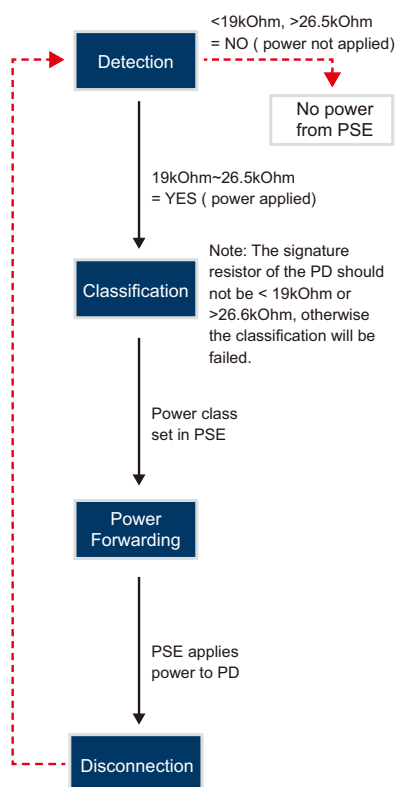

- \* Detection retry should occur within 2 seconds
- \* Time from Detection to power on PD must be < 900ms
- \* Device removal and turen off power must be < 400ms

### 3. Power Forwarding

Once power delivered, PSE continuously monitors the PD current draw for operational safety. If the draw drops below minimum values or user puts a

powered cable to a non-PoE device, the PSE will stop supplying power to avoid damage.

### 4. Disconnect Protection

There are two detection schemes defined in the standard: DC and AC Disconnect. DC Disconnect method removes power when PD current falls below a given threshold (5 to 10 mA) for a given time (300~400 mSec). AC Disconnect superimposed a probing AC voltage on the power

and measures the impedance. AC Disconnect method removes power when the impedance is larger than 27kOhm or 1980kOhm and the AC voltage is found for a given time (300~400 mSec). When the PD is removed or the power overload happens, it will go back to the detection stage.

## 1.3. How PoE Benefits You

As the first truly international power distribution standard, manufacturers do not need to develop separate products for different power standards. The ability to supply power directly to each network element over the data cables increases design flexibility. Hereafter, the benefits of PoE are numerous from both a network efficiency standpoint as well as a cost standpoint.

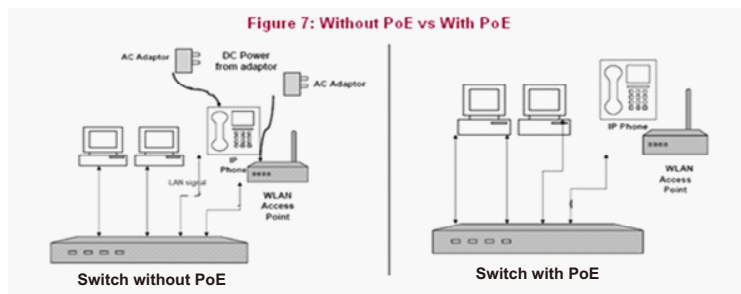

Some of major benefits are listed as below:

#### Simplicity, Cost-Effectiveness and Time-Saving

By integrating various functions into a single device, it is no longer necessary to install separate power cables, conduits, AC outlets for each device, which requires larger area for network installation. System integrators and network installing companies not only reduce space, but also significantly reduce network infrastructure budget:

- **Labor** cost reduction (AC power line wiring)
- **Material** cost reduction (AC power cord, safety component, protective plastic tube)

The time spent on installing power system is also cut substantially.



### **Mobility and Flexibility**

Ethernet appliances no longer need to be close to power source. Thus, systems like IP cameras and wireless access points can be easily located in remote places.

### **Improved Reliability**

By managing the PSE to a UPS, the power supply can be guaranteed even during mains power failure. Hence, UPS can be used to ensure service during black-out.

### **Safety**

The PoE brings safer power delivery as no high voltage main wires are needed in remote locations.

### **Energy Management**

PoE makes centralized control and management over the power distribution possible. By using a managed PoE switch, users can increase power utilization and schedule the power control for the devices, control power at non-duty times, efficiently manage and troubleshoot power consumption and/or failures.

### **Environment Maintenance**

In old buildings, colleges, museums or in locations, where running electrical power might be problematic, it becomes quite difficult to install surveillance cameras and to build a networking infrastructure with all the complex cabling systems. PoE allows network installation companies to easily build networks in hard to wire locations.

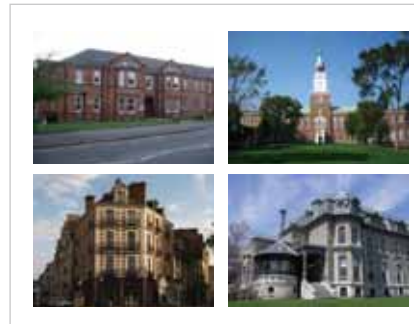

## Chapter 2. Getting More Power: From A to A+

### 2.1. PoE+ Market Growth

With the stable growth and adoption of the PoE technology, the needs have driven IEEE to formulate a new group, IEEE802.3at, which has been ratified in September 2009. The group, commonly known as PoE Plus, aims researching the next generation of PoE, with the main goal of increasing the maximum power rating to 30 watts per port. This enables the deployment of new categories of PoE devices, including multi-band access points, WiMax base stations, notebooks, video phones, motorized cameras, etc.

Some of evolving applications that require high power are listed in Table 2:

Market	Application	Power
Wireless	802.16 access points (Wimax)	20~30W
	802.11n access points	~20W
Surveillance	PTZ IP cameras	20~30W
New Markets	RFID readers	20~30W
	802.16 base stations	20~30W
	Residential gateways	~20W
	Industrial sensors	20~30W
	Ultraportable laptops	40~50W
	Notebook laptops	50~70W
	POS + information kiosks	40~50W

Table 2: Examples of High Power Requiring PDs

### 2.2. PoE vs PoE+: Technology Differences

IEEE 802.3at High Power PoE (PoE+) has a number of enhancements when it comes to powering devices and communicating data. It is a superset of the 802.3af, because it provides all the same functionality, and even more. The new standard offers new opportunities for users to significantly improve networking infrastructure cost and energy efficiency, and helps squeeze even more usefulness out of Cat 5e and above cabling infrastructures while expanding PoE's benefits to a much broader range of applications.

#### Cabling, current, voltage and wattage

To deliver high power, different cable, current and voltage are used under the IEEE 802.3at standard .Figure 8 highlights the wiring architectures of PoE and PoE+ technologies.

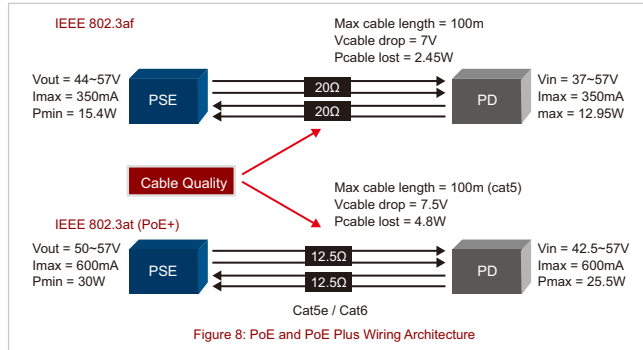
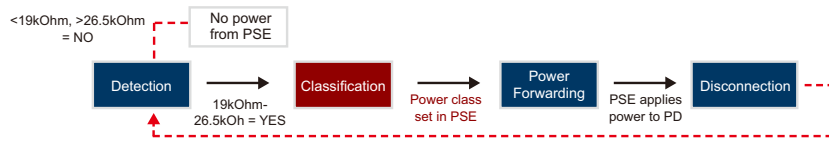

Figure 8: PoE and PoE Plus Wiring Architecture

As can be spotted in the figure, the newly released IEEE 802.3at PoE+ standard uses enhanced PoE Cat5E (Cat.5e or Cat.6) cable. The new standard enables PSE to provide increased current from 350mA to 600mA, while improving the minimum voltage output from the PSE from 44V to 50V and reducing the worst case resistance assumed to exist on the channel from 20 Ohms to 12.5 Ohms.

## Classification

The power delivery procedure by the IEEE 802.3at standard is the same as the one defined for IEEE 802.3af devices. The only difference is the classification method, which has different behavior when using the IEEE802.3at PoE+ standard.



Because different power ranges are needed by various PDs, IEEE802.3at standard, as the IEEE 802.3af, defines an option to classify PD into classes according to their power consumption, so that the PSE can apply power more efficiently.

IEEE 802.3at uses Class 4 to send 30W power from the PSE, in which case the PD will receive not more than 25.5Watts power. Thereby, for higher power requiring applications this method can be of no use.

Class	Usage	Maximum Power Levels Output at the PSE	Maximum Power Levels at the PD
0	Default	15.4W	0.44 to 12.94W
1	Optional	4.0W	0.44 to 3.84W
2	Optional	7.0W	3.84 to 6.49W
3	Optional	15.4W	6.49 to 12.95W
4	Valid for 802.3at (PoE+) devices, not allowed for 802.3af (PoE) devices	30W	12.95 to 25.50W

Therefore, in 802.3at PoE+ standard different power classification methods are provided for users to ensure increased power supply to high-end devices. These enhancements include the 1-event and 2-event classifications referred to as Physical Layer classification, which is considered as a stable and critical method to enable higher power applications, and the Link Layer Discovery Protocol referred to as Data Link Layer classification, which is a more flexible mechanism of power supply.

## 2.3. PoE+ Advantages over PoE

### High Power Capacity

The new enhanced CAT. 5e cabling type used in the IEEE 802.3at standard ensures a higher current (600mA) and minimum voltage output (50V) than the cable used in 802.3af. Besides, the resistance of the cable is also reduced to 12.5Ohms. All of these enables users to dynamically supply up to 30W high power to the powering devices.

### Powering on Demand

The IEEE 802.3af standardized PSEs and the ones compliant with IEEE 802.3at high power PoE standard can deliver power through different classification methods. If in the case of 802.3af (PoE), the PSE device can send single classification pulse (1-Event Physical Layer Classification) to check if the device in the other end of the cable is PD, the IEEE 802.3at standard brings more advantages to PoE network system constructors. It includes the earlier 1-Event Physical Layer Classification of the original 802.3af standard for backward compatibility with the earlier 15.4-maximum wattage requirement. Additionally, it provides a 2-Event Physical Layer Classification and Data Link Layer Classification mechanisms.

1) Use of the **2-event classification mechanism** between IEEE 802.3at PSE and PD aims to provide mutual identification by enabling dynamic negotiation of power, leading to a more efficient system power management without the need of using other protocols, and therefore, saving costs.

2) The **LLDP** in its turn, allows equipment system integrators to manage their power supply costs and efficiencies at levels not possible with previous standards, and most importantly, to cut their costs in the system. In this regard, the Dynamic power management mechanism is a more flexible Layer 2 power classification method.

The use of LLDP for power classification provides "fine grain" PoE power allocation of 0.1 watt granularity, along with the ability to dynamically reallocate power.

By using the ongoing dynamic re-negotiation of the IEEE 802.3at LLDP PoE, the PD devices can perform more intelligently. Hence, when using the data link layer classification, the power may change many times during PD operation.

3) Besides this, in IEEE 802.3at standard, the PSEs can provide high power while combining different mechanisms, such as:

- **2-Event + Data Link Layer (LLDP)**
- **1-Event + Data Link Layer (LLDP)**

In IEEE 802.3at standard the PSE must support one of the mentioned above classification mechanisms, while the PD must support all of them: LLDP, 2-event Classification, 1-Event + LLDP and 2-Event + LLDP.

Below figure showcases an example of 2-event classification method along with the LLDP packet usage.

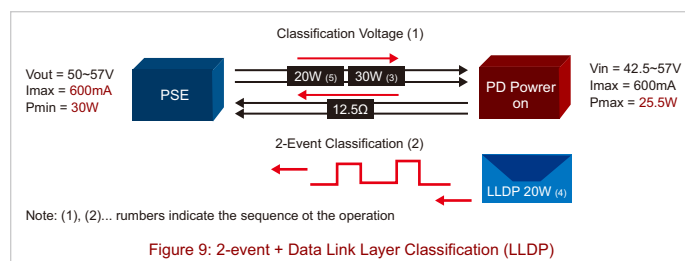

Using both mechanisms from the same device enables users to have smart and more dynamic power request and re-allocation power, improve management between PSE and PD, and achieve power saving. Considering the listed advantages of the 2-event classification method and LLDP protocols in addition to the 1-event, the IEEE 802.3at enabled PSEs are clearly capable of offering intelligent, flexible and a more economic power delivery in industrial applications.

### PoE and PoE+ Quick Comparison

Table 3 summarizes the main differences between the IEEE 802.3af and IEEE 802.3at Power Sourcing Equipment and Powering Devices:

		IEEE 802.3af	IEEE 802.3at
<b>Cable</b>	Delivery method:	2 Pairs	2 Pairs
	Paired Cabling Return Loop	20Ω	12.5Ω
	Cabling	Cat.5~	Cat.5e~
<b>PSE</b>	PSE Deliver drawn (Max)	15.4W	30W
	PSE Output voltage	44~57V	50~57V
	Max PSE output current	350mA	600mA
<b>PD</b>	PD Power drawn (Min)	12.95W	25.5W
	PD Input voltage	37~57V	42.5~57V
	Max PD current	350mA	600mA
<b>Classification</b>	Methods	*1-Event *1-Event+Data Link Layer (LLDP) *Data Link Layer (LLDP)	*2-Event *1-Event+Data Link Layer (LLDP) *2-Event+Data Link Layer (LLDP)
	Classification class	0,1,2,3	4

Table 3: IEEE 802.3af and IEEE 802.3at Comparison (PSE Device)

# Chapter 3. PoE Challenges for Industrialized Applications

## 3.1. Industrial PoE Application Markets

Due to the large number of benefits offered by PoE, its popularity and deployment has grown significantly over the past years. There are some applications in particular that benefit most from the use of PoE infrastructure. Some of these typical PoE deployments are summarized below:

### Bus Surveillance

Demand for on-bus video surveillance is growing due to the increased number of criminal threats. In this view, the emerging technological innovations and the evolution of IP video surveillance are

combining to provide bus network system integrators with efficient remote video monitoring solutions.

#### Requirements of Bus Network Infrastructure:

- Lower cost and easy installation
- DC-to-DC power converter between bus battery (24VDC) and PoE IP camera (48VDC)
- Unstable environmental conditions: temperature variations, vibration, shock etc.
- Standard compliance for bus deployment

#### PoE Benefits :

- PoE switch delivers power to the PoE IP video cameras through the data cable. Without the additional power infrastructures and wiring, PoE is a cost-saving solution fitting into the limited storage space.
- By adopting PoE Switch with on-board 12~24V power boosting technology, it becomes possible to use 24VDC power from bus battery and forward to a 48V DC PD. This eliminates the need of using additional device and requires the PSE to accept wider range of power input to provide a more simple and effective solution when implementing PoE into most transportation systems.

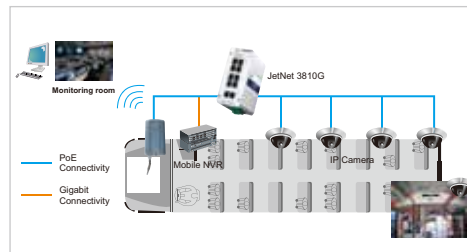

- Industrial PoE switches with rugged aluminum enclosure, solid connectors and wide operating temperature range withstand vibration and shock on moving vehicles.
- The e-Mark certification compliant switches correspond to bus deployment requirements and guarantee the reliable operation on-board vehicle.

#### Similar PoE deployments:

- Moving Vehicle Monitoring and Surveillance, Police Car Surveillance during Patrolling, Forest/Camp monitoring using solar power panels, Railway/subway carriage monitoring....

## Urban Security and Communication

Modern cities must protect citizens and businesses from a wide spectrum of risks i.e. terrorism, crimes, natural catastrophes, and other emergencies. As video security networks continue to migrate to IP network solutions, high speed Dome cameras, designed to operate in any weather conditions,

are being installed throughout cities. Additionally, with the recent boom of telecommunication industry, wireless becomes basic tool for normal functioning of any city's infrastructure, thus requiring PoE enabled WiMax systems, Wireless APs for simplifying city network infrastructures.

### Requirements of Urban Network Infrastructure:

- PSE with over 15.4W per port power delivery to High-End PDs for high reliability
- PoE to link Base Station Units and cameras to high-speed backbone network for data communication
- Network redundancy
- Remote management of network and device
- Withstanding severe conditions in outdoor areas (shock, vibration, humidity, dust, and extreme temperature variations, etc.)

### PoE Benefits :

- High-power PoE switches power High-end cameras, WiMax systems with 30W per port by IEEE 802.3at configured ports as well as standard PoE cameras with only 15.4W per port by IEEE 802.3af configured ports.
- Using gigabit combo ports, switches can uplink collected high bandwidth, high speed information through backbone network to control room.
- By running RSTP, MSTP and MSR redundancy technology with <5ms recovery time, switches provide redundant uplink connectivity without data loss or collision.
- Equipped with outstanding management functionalities, PoE managed switches ensure high quality of transferred video streams.  
Through the JetView Pro and LLDP, administrators can automatically discover over 1000 switches and perform efficient remote network management.
- Switches with rugged enclosure, RJ45 Ethernet connectors, -40~60°C wide op. temperature can resist harsh outdoor environments and ensure reliable connectivity.

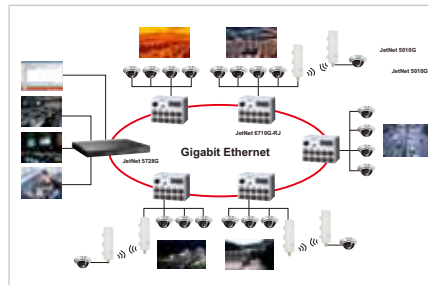

### Similar PoE deployments:

- Highway Traffic Control, Intelligent Transportation Systems, City Surveillance, Public Utility Monitoring (Oil, Gas, Damb Surveillance)...

## Subway Monitoring

Trains equipped with Ethernet capability are the wave of the future. Ethernet network carries all types of data needed for control, security and passenger information. Each railcar is installed with IP cameras to be powered by 48V power source and connected to the monitoring room for

further data control. Increasingly, PoE is chosen to be the preferred solution which simplifies network architecture, reduces installation costs/time, as a result providing optimized remote management of cameras, monitors etc .

### Requirements of Subway Network Infrastructure:

- Power converter for railcars which possess 24VDC power source and lack of 48V DC
- Gigabit for high speed and large megapixel video uplink
- Mechanical & connectivity robustness to resist vibration/shock on moving platforms
- Network redundancy for reliable video delivery without loss
- Remote network management

### PoE Benefits:

- High-power PoE switches power High-end cameras, WiMax systems with 30W per port by IEEE By implementing a booster PoE switch, system integrators eliminate the need of using separate powering devices. The switches use their built-in booster technology to transfer the 24V power to 48V while delivering 15.4W power to the IP cameras and other PoE enabled devices inside carriages.
- Booster PoE reduces installation, maintenance time and cabling costs of total IP surveillance solution. Gigabit ports uplink high-bandwidth video streams from cameras and data packets from RFID readers to the control room.
- Designed in rugged enclosure with solid M12 connectors, the EN 50121-4 railway EMC compliant switches provide reliable and high quality network communication while resisting to vibration and shock on-board railways. The smart auto thermal detection enables switches to maintain cameras and other PD devices under specific temperatures.
- System integrators can improve quality of the data transmission through IGMP snooping and QoS which provide video precedence transmission, remotely manage through SNMP and LLDP as well as ensure network redundancy with less than 5ms link recovery time through the supported MSR.
- EN 50121-4 switches ensure that they comply with all the requirements for efficient installation in railway tracksides, on board railways, train carriages etc.

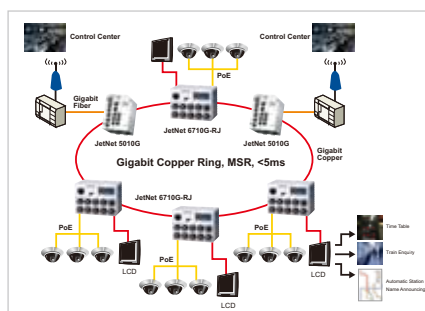

### Similar PoE deployments:

- Railcar Surveillance, Carriage Monitoring, Passenger Information System in Subways/Railways....

## Airport Security & Surveillance

Millions of people walk through airports on a daily basis, and with that, security is a major concern to detect and identify potential threats and attacks. With the boom of modern technologies and the demand of powerful safety and security solutions for passengers, high-end cameras with outstanding functionalities are being integrated

in airports' surveillance network infrastructures, covering a large area. Therefore, high port density switches with high power PoE capability are a must for implementing in airport surveillance network projects aiming to reliably collect all the megapixel video streams in a real-time basis.

### Requirements of Airport Security Network Infrastructure:

- High port density switch for connectivity to a lot of security cameras in the area
- High Power to drive High-end PTZ cameras
- Long Distance and high speed data transmission
- Redundant network for reliable connectivity
- Management functions for high quality video distribution

### PoE Benefits:

- Up to 24 IEEE802.3at enabled PoE ports deliver up to 30W power per port for driving the High-end cameras on sites. Additionally, with 2-event and LLDP classification methods, users can provide power budget control via the switch to dynamically reallocate power in cases, when the cameras need exact high power delivery, which greatly saves energy.
- Using Gigabit combo ports switches can provide high-speed fiber uplink to connect with backbone switches in different distance applications and therefore provide quick and reliable delivery of large megapixel video streams to the airport data control center.
- By using 9K Jumbo Frame feature switches transmit large video packets with fewer segments.
- Network reliability is ensured through the MSR redundancy technology.
- Supported various Layer2 management features, such as DHCP option 82, QoS, 255 VLAN groups, IGMP Snooping, LACP link aggregation etc. guarantee the highest quality of video transmission.

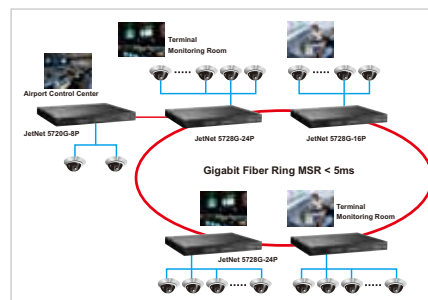

### Similar PoE deployments:

- Intelligent Transportation Systems, Highway/Railway Surveillance, Public Utility Surveillance ...

## 3.2. Industrial PoE Challenges

Rather than using commercial PoE apparatus to deploy PoE in industrial environments, various challenges need to be considered. Environmental conditions, reliability and available power are some of the key considerations in whether to use an industrial grade PoE device over a commercial grade.

### Hazardous Operating Environment

Typically commercial grade equipments are being housed in clean, safe and temperature controlled environments, moreover, are allowed to have fans to release heat which is produced during operation. Besides, in indoors the power requirements of networking devices are not high. Contrary to this, lots of challenges need to be addressed by PoE devices installed in industrial outdoor environments, including the high power feeding in hot, dusty and humid storage areas without air conditioning and under vibrating and shock environments.

### Power Input

#### ■ Deliver standard 48VDC from 12 or 24V Power source

In buses, vehicles, trains or other public transit systems power supply is usually DC 12V or 24V. This does not fall in the range, from 44VDC to 57VDC, defined in the IEEE802.3af standard and required by most of the PDs. In these circumstances an additional voltage transformer may solve from 12/24V to 48VDC power conversion problem. However, it may not meet the requirements for some particular reasons, such as cost, space limitation, etc. This becomes another challenge for the PSE manufacturers to achieve the needs for diverse industrial applications.

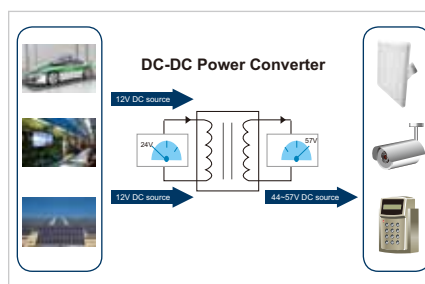

#### ■ Deliver Reliable Power

Guaranteeing power delivery is of high importance, as any power failure occurred in the system may lead to shut down of the powered device, which will lead to data loss.

### Power Output

#### ■ High Power Supply & Total Power Budget

Driven by the benefits and the evolution of the technology more and more high power consuming PDs are coming to the market. WiMax base stations and PTZ cameras are some of the best examples already seen today which require over 15Watts or even over 30Watts power per port. Moreover, these and other solutions also have high total power budget requirements (>200 Watts).

#### ■ Non-Standard Power Feeding

In many cases the PDs are not standard. Thereby, to work in industrial environments, the PSE should be able to provide power to these non-standard PDs.

#### ■ PoE Data Link Layer Classification

PSE devices feature different powering mechanisms to help enable the non standard PoE. With the emerging power hungry device market and the need for energy saving, network managers begin to take a more refined approach to powering the network. Therefore, the role of the PoE LLDP powering mechanism becomes more important, as it allows optimizing power delivery.

### Power Control

While the power demand is considered when adopting PoE technology, it should be as well considered that the amount of power drawn by the PSE must not cause any damages to the PD, cable, or the PSE itself. In this regard, PSEs should provide:

#### ■ Power Limitation

Power delivery generates heat, and as a result, bundling of the cables may exacerbate the heating problem. For safety concern, if either PSE or PD is not well designed to comply with the standard, the power delivery should be well controlled by some means to avoid overheating.

#### ■ Power Management

Acting as a power source, a PSE applies power to one or more PDs, therefore, a single PSE failure may lead to the shut down of a number of PDs. As a result, both the reliability of PSE itself and its power input become two critical points to which must be given thought. Therefore, PoE switches with power management functionality should be implemented to be able to recover any failure of Powered devices.

### Network Management and Reliability

In industrial environments it may not be enough to power on a PoE device and let it go by itself. Advanced monitoring and management on each PD, PSE or even on each port of a PSE are important to IT staff for meeting system maintenance requirements. Transmission devices are featuring more intelligence, making them smart edge devices.

#### ■ Easy-to-use Utility

To manage devices in large networks, administrators need user-friendly management tools, such as SNMP.

#### ■ Full Network Layer 2 Features

To ensure high-quality performance, bandwidth aggregation and efficient video stream transmission in industrial surveillance networks, PSE devices should provide advanced layer 2 management features, such as QoS for video precedence transmission, VLAN for traffic isolation, IGMP snooping for one-to-many video transmission, DHCP for automatic IP configuration, and much more others.

#### ■ System Redundancy

Reliability is a necessity for industrial usages. It is highly important for industrial applications to remain running smoothly. Any single point failure may result in loss of video streams. Therefore, network redundancy mechanisms with a very short recovery time should be implemented.

## Remote Control and Mobility

With the visualization becoming more important and the networks more complex, providing simple data connectivity through traditional networking control equipment is often not enough to build reliable network infrastructures. Hereafter, computing and routing should be performed in order to have a complete and efficient networking system.

### ■ Industrial System Control

Today's industrial control or automation applications require more visualization; not only is it important getting the data from devices, but also getting live images of the devices when accidents occur. Therefore, for network efficiency, in addition to PoE capability for image capturing, it is equally important to be able to remotely control the connected devices through various gateways .

### ■ Mobility

The requirements of complex network settings become more sophisticated. Therefore more flexibility of switches or routers is needed. To set up networks Web UI is used which, however, is for specific usage only, as the setting steps are fixed, and it is easy to follow up users. Environmentally tailor-made settings could be done only by programming, such as the Linux. Other than this, to simplify installation and mobility, comprehensive routers are often needed which make data transmission across Internet and to multi-sites feasible.

### ■ Compact All-in-One Capability

With everything going for Internet and requiring higher mobility, more and more network nodes are created with limited space and installation costs. This generates a need for all-in-one devices.

## Chapter 4. Leading Industrial PoE Solutions: Going Beyond A+

Korenix, a leader in the PoE market offers switches that are designed with powerful functionalities to fit and exceed all the challenges for industrial PoE applications. From reliable power input to aggregated power delivery and control, to management and remote programming and most importantly to the industrial thermal issues – all of these are addressed through Korenix complete ruggedized PoE solutions. These solutions consist of Managed and Unmanaged PoE switches, compliant with both

IEEE 802.3af and High Power IEEE 802.3at PoE standards and delivering up to 30 watts power per port via RJ45 cables along with the highest quality data. With over 500W total power budget per unit, Korenix's PoE switches outstand from competition and fulfill local increasing PoE demands. Furthermore they are designed with wide operating temperature and rugged fan-less design, featuring IP30, IP31 and even IP67 grade protection, vibration and shock resistance for performing reliably in industrial environments.

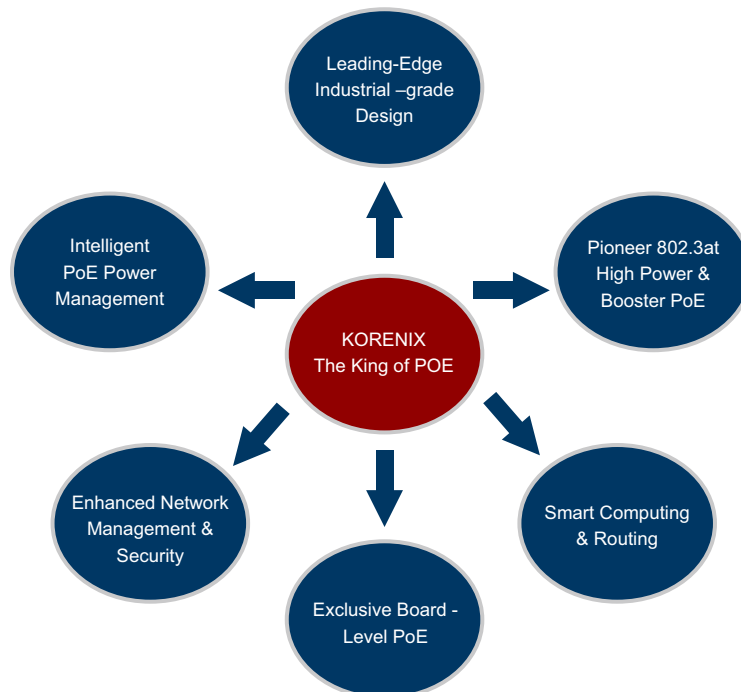

## 4.1. World's 1st Industrial PoE Technologies

### Critical Power Delivery via Pioneer High Power & Booster PoE technologies

#### ■ 12~24V PoE Boost Capability for Transit Surveillance

To fulfill vehicle, bus and other applications that require switches with exceptionally 24VDC power input, Korenix brings the world's first PoE solutions to the market, which are designed with a built-in 12V or 12~24V to 48V PoE Boost technology. This makes the deployment of standard IEEE 802.3af PoE IP cameras feasible on bus, railcar, water vessels and other applications which lack of 48VDC power source. The JetPoE series switches and JetBox series computing platforms can be perfectly installed in compact locations without using additional connections which further complicate the network, and therefore making the total systems more reliable and cost-saving.

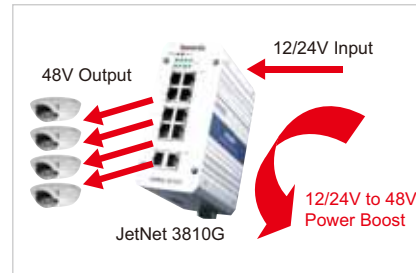

#### ■ Redundant Power Input

To ensure power availability and reliability, PoE switches are designed to support dual power inputs which can be connected to separate power sources or connected to UPS system as the extended power source. The backup power input will be enabled when the main input fails.



#### ■ Global Exclusive 30W High Power PoE supply

Korenix designs a wide range of Industrial IEEE 802.3at High Power PoE solutions which are capable of delivering up to 30 watts per port and over 500W per unit high power through various powering mechanisms to fulfill local increasing PoE demands. As a result, they fit best for highly critical PoE applications, such as real time IP video surveillance with high resolution quality and the evolving demands of wireless communications such as WiMax and 802.11 a/b/g/n Access Points.

#### ■ Over 500W Total Power Budget through Power Aggregation

Korenix switches are designed with power aggregation capability, which allows them to maximize power supply to power hungry devices. By aggregate the power from different power sources, the JetPoE series can deliver up to 500W total power from the unit to the existing PD.



■ **Efficient Powering Mechanism**

**Dynamic Powering via IEEE 802.3at LLDP PoE**

Korenix's latest released high power PoE switches implement the Link Layer Discovery Protocol (LLDP) of IEEE 802.3at High Power PoE into the system for efficient power budget negotiation. The LLDP packet provides smart power budget control behavior to fulfill the needs of higher end

setups requiring exact high power delivery. By using the ongoing dynamic re-negotiation function of the IEEE802.3at LLDP PoE, these outstanding PoE devices can perform more intelligently by dynamically reallocating power to the PDs. Thereby, they can also enable system integrators to use the power in a more economical way.

**Efficient and Software configuration-free Powering via IEEE 802.3at 2-event PoE**

The IEEE 802.3at 2-event classification method is supported in Korenix's JetPoE series providing PoE power budget management between PSE and PD devices and allows PD devices request up to 30W power from switches via the PoE chip behavior without implementing additional software. This, as a result, allows switches to efficiently power High-End PoE Devices in an easy way without software configurations.

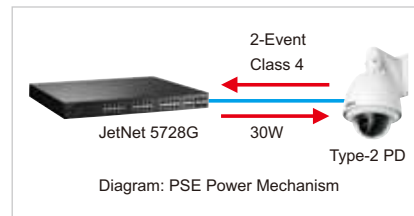

**IEEE 802.3at 3rd Party PSE Conformance Tested**

The JetPoE series rackmount high-power PoE switches have been tested by Korenix and a 3rd party organization for the conformance and inter-operability of the new IEEE 802.3at 2-event

and IEEE 802.3at LLDP technologies, thus, guaranteeing their capability of intelligent power delivery, high performance functionality and reliability.

■ **Forced Powering Mode for Proprietary High-Power Feeding**

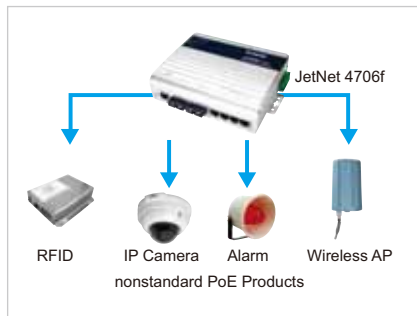

Korenix integrates advanced forced powering control feature in its switches to deliver power to those non-standard PoE devices that cannot be detected as valid PDs. In the early days PoE products that were circulating the market prior to the ratification of PoE 802.3af standard, did not comply with the current standard and did not support PD detection and classification. The PoE switches were unable to recognize the PD, and therefore, could not forward the power. The forced powering ability of JetPoE series solves this problem, enabling all your PDs.

■ **Pioneer 4 Powering Modes for Flexible Applications**

To be compatible with different PDs, Korenix industrial rackmount PoE switches are designed with 4 powering modes, including IEEE 802.3af mode, IEEE 802.3at 2-event, IEEE 802.3at LLDP classification modes as well as forced powering

mode to meet all of the PD types in the industry. As a result, they can be flexibly used to deliver power for different PoE-enabled devices in various application.

## Reliable & Economic Powering via Intelligent PoE Power Management Technologies

### ■ Priority Control for PD Power Budget Limitation

Korenix JetPoE series PoE switches provide auto budget and priority control to limit total output power in case if a PD device is not claimed right consumption numbers. Once the total power supply exceeds the limit installed by user, the switch will automatically turn off the lowest priority ports. This will allow users to protect high priority PD devices from shut down caused by overloading of the power supply.

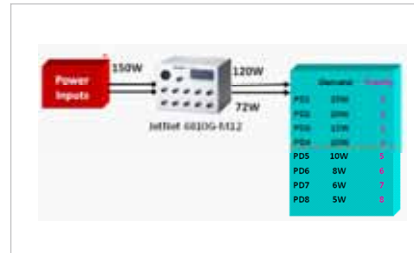

### ■ Power Aggregation Management

Korenix has designed JetPoE series rackmount managed switches with Power aggregation management capability, which allows the devices to determine the exact power draw per port and to balance each port PoE power output accordingly. This, in turn, allows the switch to power higher and lower wattage devices according to user-definable parameters such as maximum available power, port priority (critical, high, low), and maximum allowable power per port.

### ■ “Link Partner Line Detect” for Smart Powered Device Alive-Check

The JetPoE series switches can be configured by Korenix patented PoE “Link Partner Line Detect” technology to guarantee the reliable connection of PD devices through easy monitoring of their real-time status. Once the keep alive checking detects PD failure, it resets the PoE port to bring the PD back to a working state. This greatly enhances the system reliability while minimizing the maintenance time and cost.



### ■ PoE Power Scheduling

To ensure advanced power control, Korenix’s PoE switches provide an hourly/weekly scheduling mechanism. Each PD device connected to a designated PoE port can be configured as on/off by hourly basis. This feature meets economical power management, security, or customer-specific requirements.

## Outstanding Industrial-grade Design via Leading-Edge Ruggedization Technologies

### ■ Industrial Grade PoE for Severe Environmental Applications

With extended temperature components, no moving parts and fans, Korenix industrial-grade PoE switches are capable of operating under harsher conditions than commercial grade devices. Equipped with IP30, IP31 and even IP67 grade platforms, these industrial switches work effectively under harsh environments exposed to dust and high humidity.

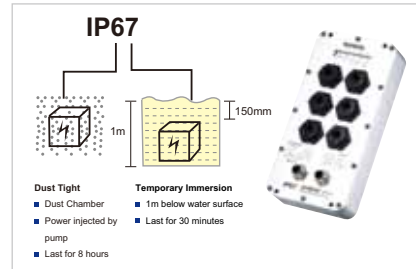

### ■ Solid RJ45 / M12 Connectors against Vibration and Shock

Korenix design PoE switches with RJ45 and M12 connectors resistant to vibration and shock in order to best fulfill the requirements of various applications. Equipped with M12 D-coded connectors, the PoE switches can be used for upgrading industrial applications while delivering power along with data to PD devices

in industrial machinery, factory automation, railways, marine applications etc. For outdoor networking applications, such as telecom, outdoor surveillance, wireless AP connections, PoE switches with rugged RJ45 Ethernet connectors can be ideal solutions.



### ■ Intelligent Auto Thermal Detection for PD Setting

Korenix's JetPoE managed Booster switches adopt thermal detector to ensure the reliable operation of DC booster under safe temperature by smartly checking DC booster temperature and adjusting to it available PoE output. When the power supply is degrading due to ambient temperature, PD will shut down by priority. This makes the PoE switch an intelligent power control device that helps users maintain the PD devices under specific temperatures and hence, ensure critical PD reliability.

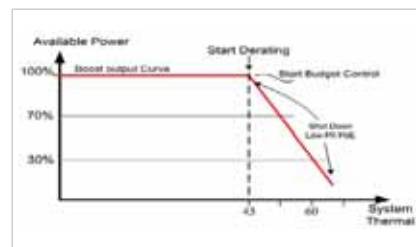

### ■ Isolated Booster for Safe Power Delivery

The DC Booster of Korenix managed PoE switches is designed with Hi-pot isolation feature to protect the device from the lightning and surge of the Ethernet and therefore, allowing the switch efficiently power outdoor PD equipments under severe conditions.

## Exclusive Board-Level PoE Solution for Embedded System

For those applications which have limited installation space and require PoE capability to power up IP cameras, IP phones, wireless access points,... the ability to provide an embedded PoE board solution is a key factor for successful network implementation.

### ■ UPCI Add-on Card for Easy System Expansion

JetCard 2215 is a 32-bit Universal PCI form factor card with Windows or Linux drivers. Users can benefit from the UPCI capability of the card to easily install it in already existing UPCI cabinets for adding PoE functionality into the control room for future surveillance.

Other than this, using the easy-to-install drivers that come with JetCard, the small-sized device can be easily set up in an IPC system with or even without UPCI connection (it can be connected using its reserved 5th LAN port). As a result, this will enable network integrators to extend their system or combine the card with other boards or add-on software to design a more complete customized surveillance system.

Korenix designs add-on PoE card that can use its power as well as Ethernet capability and flexibility to easily fit in and extend the system, as a result dramatically reducing time-to-market by contributing to the delivery of best image quality at the lowest available cost.

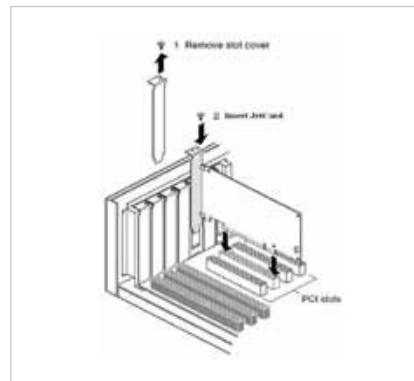

### ■ IEEE 802.3af PoE for Cost-Effective Video Surveillance

JetCard 2215's compact interface integrates 4 IEEE 802.3af compliant PoE ports, which enables users to add into the embedded system a powering capability for video surveillance. The PoE simplifies system installation and significantly reduces maintenance time and costs of the total surveillance system.

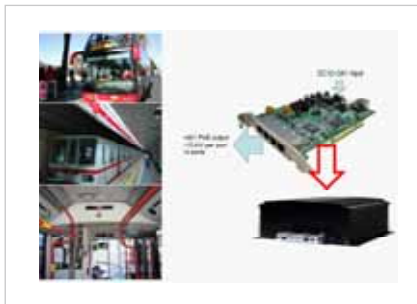

### ■ Exclusive 12~24V Booster for 48V PoE

JetCard 2215 is equipped with an on-board 12~24VDC power input module which allows JetCard to adopt the 12~24VDC power input and boost it to 48V power output for 802.3af standard PoE devices. As a result, it can be used in embedded devices to make the deployment of standard IEEE 802.3af PoE IP cameras feasible on locations, such as on-board buses, railcars, police cars, carriages or any other automation sites, where 48V power source is not available.

## Enhanced Network Management and Security for High-Quality Networking

### ■ Outstanding Network Reliability by MSR

Korenix provides devices with various redundant ring technologies to recover link failures and ensure reliable data transmission within small timeframe. In traditional star networks, any unexpected link failure results in loss of all the data transmitted on the path.

By implementing the Korenix MSR (Multiple Super Ring) network redundancy technology, users can be assured that any link failure will be recovered in just 5ms. As a result, all traffic will be protected from any network failure and will be resumed even

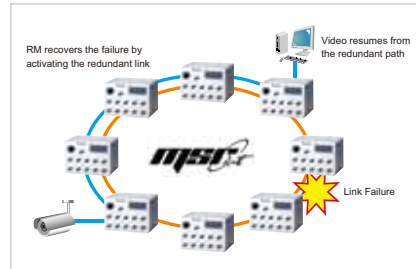

without being noticed. Hence, no critical point can be seen in this fast-recovery topology.

### ■ LLDP for Automatic Topology Discovery

Korenix managed switches support topology discovery or LLDP (IEEE 802.1AB Link Layer Discovery Protocol) that can help users discover multi-vendor's network PSE on the same segment by an NMS system, which supports LLDP function. With LLDP, NMS can easily maintain the topology map, display port ID, port description, system description, etc.. Once a link failure happens, the topology changed events will be updated to the NMS to help users easily maintain the PoE network system.

### ■ Efficient Real-Time Network Management through JetView Pro i<sup>2</sup>NMS

Korenix managed switches feature SNMP, which allows remotely managing all PoE settings. Using remote management, system administrators can easily power cycle any or all PoE devices in the network by disabling and then re-enabling power to the specified ports. They can as well create scripts to monitor power usage on all the blades or any given port within a switch by doing periodic SNMP queries of the MIB objects.

Other than the SNMP and LLDP protocols, Korenix managed PoE solutions efficiently work with the Korenix patented JetView Pro i<sup>2</sup>NMS, which in addition to auto topology discovery also delivers MSR™ group management, group IP assignment, firmware upgrade, configuration file backup/ restore, SNMP MIB Browser / compile, etc. With the user-friendly software, administrators can discover devices automatically and manage the performance of the large-scale industrial networks in a real-time basis.



### ■ Advanced L2 management for High Quality and Secure Networking

To fulfill the advanced management, control and security requirements of surveillance network, Korenix PoE solutions incorporate advanced Layer2 management protocols, such as the DHCP option 82, 256 VLAN, LACP, QoS, IGMP snooping, etc. for providing real-time and high quality data transmission along with power delivery and therefore, efficiently controlling and managing the PoE-enabled network performance.

## All-in-One Smart Computing and Routing Solution for System Extension & Easy Remote Control

Korenix answers the market need for all-in-one mobile PoE solutions by providing its programmable PoE platforms, which in addition to Power over Ethernet, integrate various networking interfaces, routing and Linux computing functions for multifunctional deployment:

**JetOS, Korenix Embedded Linux:** The JetBox series are designed with JetOS, the Korenix built-in Linux OS for user-friendly programming and remote control.

**Layer 3 Routing:** JetBox are designed with complete Layer 3 Routing features such as OSPF, RIP, DVMRP, IPv6, allowing devices inspecting incoming packets and making dynamic routing decisions based on the source and destination addresses inside.

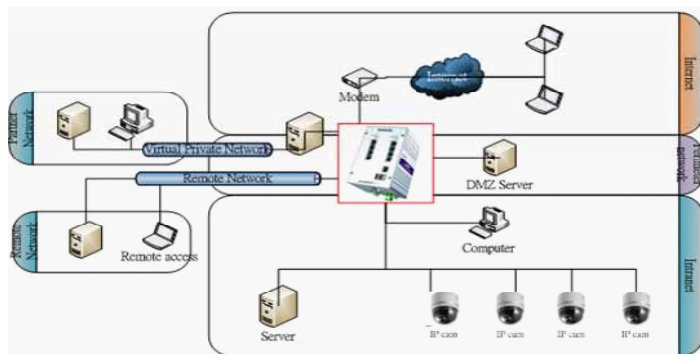

**Enriched Interface:** JetBox series are designed with multiple interfaces, including Gigabit for high-speed data transmission, Ethernet for network connectivity, PoE for IP surveillance, Serial and DIO for device and signal control, USB for data storage, etc.

All of these enable users to achieve:

### ■ Remote System Control

The rich interface capabilities allow JetBox connecting to various remote equipment, while the Linux programming enables system developers to input and use value-added software such as Webmin, JamVM, Modbus Gateway into the platform. This, as a result, enables JetBox to operate as various gateways to control devices in remote locations while simultaneously using PoE to capture the device images.

### ■ Increased System Mobility

#### Flexible Computing via Linux auto-run

Using the Linux operating system and performing only few commands, users can modify the configure file and use Korenix Linux auto-run function to execute it easily, increasing system mobility.

#### Mobile Network Extension via miniPCle & SIM Slot

Network administrators greatly benefit from the routing and computing functionalities as well as the expansion slots reserved on the JetBox 9560 series to extend the network communication via GSM/GPRS/3G/3.5G/HSUPA, and thus enhance the mobility of the devices in PoE applications. Therefore, in areas, where wired transmission is not an option, such as public transportations, trucks or railways, the extension capability of JetBox allows sending wireless data back to control center via mobile network card slots.

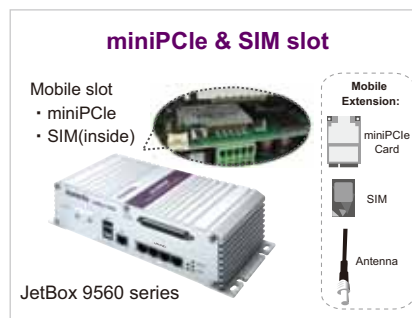

#### ■ Easy System Installation and Space-Saving

By simultaneously connecting 12~24V Booster PoE for standard 48V vehicle camera, WAN for Ethernet, USB wifi dongle for WiFi network, and miniPCle 3G module & SIM for 3G networks and by switching the links between these 4 networks using the routing function, JetBox 9560 series become perfect solutions to be easily installed in limited spaces, specifically for mobile applications, such as bus, train, and automobile.

## 4.2. JetPoE Series Switches Quick Selection Guide



JetNet 5728G -24P



JetNet 5728G -16P



JetNet 5720G -8P

### Rackmount Managed Giga IEEE 802.3at High Power PoE Switch

<b>IP Camera Compatibility</b>			
Motion JPEG, MPEG-4, H.264	•	•	•
Megapixel, HDTV	•	•	•
<b>PoE</b>			
Number of PoE ports	24	16	8
PoE Powering conductor	1,2,3,6	1,2,3,6	1,2,3,6
High Power for PTZ/IR Camera	30W	30W	30W
Total Power Budget	240W @AC(50°C) / 540W @DC(65°C)	240W @AC(50°C) / 340W @DC(65°C)	75W @AC(50°C) / 160W @DC(65°C)
24V Boost for Vehicle, Bus, Railway			
Forced Powering for Non-standard PoE Camera	•	•	•
IEEE802.3at 2-event & LLDP classification	•	•	•
<b>Interface</b>			
Fast Ethernet 10/100TX	24	24	16
Gigabit Ethernet 10/100/1000TX	4G (Combo)	4G (Combo)	4G (Combo)
Fiber Ports	4 (Giga SFP)	4 (Giga SFP)	4 (Giga SFP)
Relay Output	•	•	•
Power Input	2 x DC 46 ~ 57V AC 90~264V/DC127~370V	2 x DC 46 ~ 57V AC 90~264V/DC127~370V	2 x DC 46 ~ 57V AC 90~264V/DC127~370V
<b>Video Transmission Quality</b>			
QoS Prioritized Video Transmission	•	•	•
IGMP Optimized Multicast Transmission	•	•	•
IEEE 802.1Q VLAN Traffic Isolation	•	•	•
<b>Network and System Reliability</b>			
RSTP / MSTP	•	•	•
MSR Redundant Surveillance Network	•	•	•
IP Camera Alive Check and Failure Recovery	•	•	•
IP Camera Failure Alarm	•	•	•
IP Camera Cable Loss Alarm	•	•	•
<b>Other Protocols</b>			
Web Config/JetView/JetView Pro	•	•	•
DHCP, HTTPS, SSH, Port/IP Security, 802.1x	•	•	•
SNMP v1/v2c/v3 RMON	•	•	•
SMTP/Syslog	•	•	•
IEEE802.1 AB LLDP	•	•	•
<b>Environmental Protection</b>			
Case Protection	IP31	IP31	IP31
Operating Temperature	-25~65°C (802.3af)	-25~65°C (802.3af)	-25~65°C (802.3af)
<b>Installation</b>			
Din-Rail / Wall Mount			
Rack-mount	•	•	•
<b>Certifications</b>			
Regulation: CE/FCC/UL/CB	•	•	•
RoHS/WEEE	•	•	•



JetNet 6710G-M12



JetNet 6710G-RJ



JetNet 5710G



JetNet 4706



JetNet 4706f

	Managed Giga	IEEE 802.3at High Power PoE Switch	Managed High Power PoE Switch		
<b>IP Camera Compatibility</b>					
Motion JPEG, MPEG-4, H.264	•	•	•	•	•
Megapixel, HDTV	•	•	•	•	•
<b>PoE</b>					
Number of PoE ports	8(M12)	8(RJ45)	8	4	4
PoE Powering conductor	1,2,3,4	1,2,3,6	1,2,3,6	4,5,7,8	4,5,7,8
High Power for PTZ/IR Camera	30W	30W	30W	25W	25W
Total Power Budget	200W (60°C)	200W (60°C)	200W (60°C)	80W (60°C)	80W (60°C)
24V Boost for Vehicle, Bus, Railway					
Forced Powering for Non-standard PoE Camera	•	•	•	•	•
IEEE802.3at 1-event & LLDP classification	•	•	•	IEEE802.3af LLDP	IEEE802.3af LLDP
<b>Interface</b>					
Fast Ethernet 10/100TX	8 (M12)	8 (RJ45)	8	6	4
Gigabit Ethernet 10/100/1000TX	2G	2G	2G		
Fiber Ports					2 (100FX)
Relay Output	•	•	•	•	•
Power Input	DC48-57V x 2	DC48-57V x 2	DC48-57V x 2	DC48V x 2	DC48V x 2
<b>Video Transmission Quality</b>					
QoS Prioritized Video Transmission	•	•	•	•	•
IGMP Optimized Multicast Transmission	•	•	•	•	•
IEEE 802.1Q VLAN Traffic Isolation	•	•	•	Port-based	Port-based
<b>Network and System Reliability</b>					
RSTP / MSTP	•	•	•	RSTP	RSTP
MSR Redundant Surveillance Network	•	•	•	•	•
IP Camera Alive Check and Failure Recovery	•	•	•	•	•
IP Camera Failure Alarm	•	•	•	•	•
IP Camera Cable Loss Alarm	•	•	•	•	•
<b>Other Protocols</b>					
Web Config/JetView/JetView Pro	•	•	•	•	•
DHCP, HTTPS, SSH, Port/IP Security, 802.1x	•	•	•	•	•
SNMP v1/v2c/v3 RMON	•	•	•	•	•
SMTP/Syslog	•	•	•	•	•
IEEE802.1 AB LLDP	•	•	•	•	•
<b>Environmental Protection</b>					
Case Protection	IP30	IP30	IP30	IP31	IP31
Operating Temperature	-40~60°C (802.3at)	-40~60°C (802.3at)	-40~70°C (802.3at)	-40~60°C	-40~60°C
<b>Installation</b>					
Din-Rail / Wall Mount	Wall Mount	Wall Mount	Wall Mount	•	•
Rack-mount					
<b>Certifications</b>					
Regulation: CE/FCC/UL	CE/FCC	CE/FCC	CE/FCC	•	•
RoHS/WEEE	•	•	•	•	•
EN 50121-4 Railway EMC	Compatible	Compatible	Compatible		



JetNet 6810G-M12    JetNet 6810G-RJ    JetNet 3810Gf / 3810f    JetNet 3810G    JetNet 3806G    JetNet 3705-24V    JetCard 2215

Managed Giga 24V PoE Switch    Giga/FE 12~24V Fiber PoE Switch    Giga 12~24V PoE Switch    24V PoE Switch    12~24V PoE UPCI Switch Board

IP Camera Compatibility							
Motion JPEG, MPEG-4, H.264	•	•	•	•	•	•	•
Megapixel, HDTV	•	•	•	•	•	•	•
PoE							
Number of PoE ports	8(M12)	8(RJ45)	8(RJ45)	8	4	4	4
PoE Powering conductor	1,2,3,4	1,2,3,6	4,5,7,8	4,5,7,8	4,5,7,8	1,2,3,6	4,5,7,8
Total Power Budget	120W (60°C)	120W (60°C)	65W (60°C)	65W (60°C)	60W (60°C)	67W@DC24V 62.4W@DC48V	60W
24V Boost for Vehicle, Bus, Railway	•	•	12~24V Boost	12~24V Boost	12~24V Boost	•	12~24V Boost
Forced Powering for Non-standard PoE Camera	•	•					
IEEE802.3af 1-event & LLDP classification	•	•					
Interface							
Fast Ethernet 10/100TX	8 (M12)	8 (RJ45)	8	8	4	5	5
Gigabit Ethernet 10/100/1000TX	2G	2G		2G	2G		
Fiber Ports			2 Giga SFP (JetNet 3810Gf) 2 FE SFP (JetNet 3810f)				
Relay Output	•	•	•	•	•		
Power Input	DC24~57V	DC24~57V	DC12~24V	DC12~24V	DC12~24V	DC24/48V x 2	DC12~24V
Video Transmission Quality							
QoS Prioritized Video Transmission	•	•	•	•	•		
IGMP Optimized Multicast Transmission	•	•					
IEEE 802.1Q VLAN Traffic Isolation	•	•					
Network and System Reliability							
RSTP / MSTP	•	•					
MSR Redundant Surveillance Network	•	•					
IP Camera Alive Check and Failure Recovery	•	•					
IP Camera Failure Alarm	•	•					
IP Camera Cable Loss Alarm	•	•	•	•	•	•	
Other Protocols							
Web Config/JetView/JetView Pro	•	•					
DHCP, HTTPS, SSH, Port/IP Security, 802.1x	•	•					
SNMP v1/v2c/v3 RMON	•	•					
SMTP/Syslog	•	•					
IEEE802.1 AB LLDP	•	•					
Environmental Protection							
Case Protection	IP30	IP30	IP30	IP30	IP30	IP30	
Operating Temperature	-40~60°C	-40~60°C	-25~60°C	-25~60°C	-25~60°C	-10~60°C	-25~70°C
Installation							
Din-Rail / Wall Mount	Wall Mount	Wall Mount	Din-Rail	Din-Rail	Din-Rail	•	
Rack-mount							
Certifications							
Regulation: CE/FCC/UL	CE/FCC	CE/FCC	•	•	•	CE/FCC	CE/FCC
RoHS/WEEE	•	•	•	•	•	•	•
EN 50121-4 Railway EMC	Compatible	Compatible					
e-Mark			•	•	•		



JetNet 3710G



JetNet 3706-RJ



JetNet 3705



JetNet 3705f

	Giga PoE Switch	IP67 PoE Switch	PoE Switch	
<b>IP Camera Compatibility</b>				
Motion JPEG, MPEG-4, H.264	•	•	•	•
Megapixel, HDTV	•	•	•	•
<b>PoE</b>				
Number of PoE ports	8	4	4	4
PoE Powering conductor	4,5,7,8	4,5,7,8	4,5,7,8	4,5,7,8
Total Power Budget	65W* (70°C)	55W (70°C)	60W (70°C)	60W (70°C)
24V Boost for Vehicle, Bus, Railway				
Forced Powering for Non-standard PoE Camera				
IEEE802.3at 1-event / LLDP classification				
<b>Interface</b>				
Fast Ethernet 10/100TX	8	6	5	4
Gigabit Ethernet 10/100/1000TX	2G			
Fiber Ports				1 (100FX)
Relay Output	•		•	•
Power Input	DC48V	DC44~57V x 2	DC48V x 2	DC48V x 2
<b>Video Transmission Quality</b>				
QoS Prioritized Video Transmission	•			
IGMP Optimized Multicast Transmission				
IEEE 802.1Q VLAN Traffic Isolation				
<b>Network and System Reliability</b>				
RSTP / MSTP				
MSR Redundant Surveillance Network				
IP Camera Alive Check and Failure Recovery				
IP Camera Failure Alarm				
IP Camera Cable Loss Alarm	•		•	•
<b>Other Protocols</b>				
Web Config/JetView/JetView Pro				
DHCP, HTTPS, SSH, Port/IP Security, 802.1x				
SNMP v1/v2c/v3 RMON				
SMTP/Syslog				
IEEE802.1 AB LLDP				
<b>Environmental Protection</b>				
Case Protection	IP30	IP67	IP31	IP31
Operating Temperature	-25~70°C	-40~70°C	-20~70°C	-10~70°C
<b>Installation</b>				
Din-Rail / Wall Mount	Din-Rail	Wall Mount	•	•
Rack-mount				
<b>Certifications</b>				
Regulation: CE/FCC/UL	•	CE/FCC	CE/FCC	CE/FCC
RoHS/WEEE	•	•	•	•

### 4.3. JetBox Series Computers Quick Selection Guide



JetBox 9310



JetBox 9530



JetBox 9532



JetBox 9535

	PoE Networking Computer		PoE Routing Computer	
<b>IP camera connection</b>				
10/100M LAN with IEEE802.3af PoE (ports/connector) PoE scheduling supported	4 / RJ45 PoE pin (4,5,7,8)	4 / RJ45 PoE pin (4,5,7,8)	4 / RJ45 PoE pin (4,5,7,8)	8 / RJ45 PoE pin (4,5,7,8)
10/100M LAN				
Uplink 10/100M WAN	1 / RJ45	1 / RJ45	1 / RJ45	1 / RJ45
Uplink Throughput (bps) (All video compression formats transmission supported: MPEG-4, MJPEG, H.264)	Switching 100M Routing 2M	Switching 100M L3 Routing 80M	Switching 100M Routing 80M	Switching 100M L3 Routing 80M
<b>LAN Ethernet switch</b>				
IEEE802.1Q VLAN	•	•	•	•
QoS	•	•	•	•
<b>The Internet &amp; router</b>				
IP addressing	IPv4	IPv4, IPv6	IPv4, IPv6	IPv4, IPv6
IP address filtering	Firewall, NAT, DMZ	Firewall, NAT, DMZ	Firewall, NAT, DMZ	Firewall, NAT, DMZ
<b>Wireless networking connection</b>				
IEEE802.11 WLAN client	Optional (USB dongle)	Optional (USB dongle)	Optional (USB dongle)	Optional (USB dongle)
Mobile network client (GSM/GPRS/EDGE/3G/3.5G/HSUPA)		Optional (USB)	Optional (USB)	Optional (USB dongle)
<b>Network security</b>				
Username/password authentication	•	•	•	•
Security tunnel--VPN	VPN pass through	•	•	•
<b>Front-end management system</b>				
Power input	12~48V DC (48V for PoE)	12~48V DC (48V for PoE)	12~48V DC (48V for PoE)	12~48V DC (48V for PoE)
Power consumption	68.8W (incl. PoE) / 7.2W	90W (incl. PoE) / 25W	90W (incl. PoE) / 25W	160W (incl. PoE) / 35W
Built-in functionality: web-based UI	•	•	•	•
Open Linux platform	Linux auto-run function	•	•	•
JamVM		•	•	•
Customer-specific software	SDK provided	SDK provided	SDK provided	SDK provided
MSR		•	•	•
Other interfaces		4*RS232/422/485 (DB37)		
<b>Industrial rugged design</b>				
Anti-vibration	5g		5g	
Anti-shock	50g		50g	
Operating temp.	-25~70°C (wide temp. -40~80°C)		-25~70°C	
<b>Certification</b>				
CE/FCC	•	•	•	•
UL	•			



JetBox 9560



JetBox 9562



JetBox 9533G



JetBox 9563G

Vehicle 12~24V PoE Routing Computer

GbE PoE Routing Computer

	JetBox 9560	JetBox 9562	JetBox 9533G	JetBox 9563G
<b>IP camera connection</b>				
10/100M LAN with IEEE802.3af PoE (ports/connector) PoE scheduling supported	4 / RJ45 PoE pin (4,5,7,8)	4 / RJ45 PoE pin (4,5,7,8)	4 / RJ45 PoE pin (4,5,7,8)	4 / RJ45 PoE pin (4,5,7,8)
1000M LAN			4 / RJ45	4 / RJ45
Uplink 10/100M WAN	1 / RJ45	1 / RJ45	1 / RJ45	1 / RJ45
Uplink Throughput (bps) (All video compression formats transmission supported: MPEG-4, MJPEG, H.264)	Switching 100M L3 Routing 80M	Switching 100M L3 Routing 80M		Switching 100/1000M L3 Routing 80M
<b>LAN Ethernet switch</b>				
IEEE802.1Q VLAN	•	•	•	•
QoS	•	•	•	•
<b>The Internet &amp; router</b>				
IP addressing	IPv4, IPv6	IPv4, IPv6	IPv4, IPv6	IPv4, IPv6
IP address filtering	Firewall, NAT, DMZ	Firewall, NAT, DMZ	Firewall, NAT, DMZ	Firewall, NAT, DMZ
<b>Wireless networking connection</b>				
IEEE802.11 WLAN client	Optional (via module installed)	Optional (via module installed)	Optional (USB dongle)	Optional (via module installed)
Mobile network client (GSM/GPRS/EDGE/3G/3.5G/HSUPA)	Optional (via module installed)	Optional (via module installed)	Optional (USB dongle)	Optional (via module installed)
<b>Network security</b>				
Username/password authentication	•	•	•	•
Security tunnel--VPN	•	•	•	•
<b>Front-end management system</b>				
Power input	12~24V DC	12~24V DC	12~48V DC (48V for PoE)	12~24V DC
Power consumption	100W (incl. PoE) / 25W	100W (incl. PoE) / 25W	90W (incl. PoE) / 25W	100W (incl. PoE) / 25W
Built-in functionality: web-based UI	•	•	•	•
Open Linux platform	•	•	•	•
JamVM	•	•	•	•
Customer-specific software	SDK provided	SDK provided	SDK provided	SDK provided
Other interfaces	4* RS232/422/485 (DB37)			
<b>Industrial rugged design</b>				
Anti-vibration	5g		5g	
Anti-shock	50g		50g	
Operating temp.	-25~70°C		-25~70°C	
<b>Certification</b>				
CE/FCC	•	•	•	•

## Summary

Power over Ethernet is an emerging technology that changes the way both network and non-network devices are used. With the rapid increasing deployment of PoE, residential, enterprise, and industrial users benefit from its simplicity, reliability, flexibility as well as cost savings.

Industrial grade PoE and High Power PoE devices face diverse challenges of different power systems, harsh operating environment, and management requirement. Besides, as new power-hungry devices surface to take advantage of expanding PoE opportunities, the demand to define "high-power PoE" cable limitations is becoming critical. By providing flexible installation options, versatile power forwarding methods and outstanding management facilities, Korenix's JetPoE series overcomes practical deployment problems in industrial environment and brings the PoE technology into full play, while enabling standard, nonstandard and high-power PDs. By ruggedized fanless design and wide operating temperature range, Korenix's JetPoE series undoubtedly are the best solutions for your specific industrial PoE deployments.

## Glossary of Terms

<b>1-Event classification</b>	The application of a single class event during PI probing
<b>2-Event classification</b>	The application of two class events during PI probing
<b>10Base-T</b>	Ethernet over twisted pair runs at 10 Mbps
<b>100Base-TX</b>	Ethernet over twisted pair runs at 100 Mbps
<b>1000Base-T</b>	Ethernet over twisted pair runs at 1000 Mbps
<b>BSU</b>	Base Station Unit
<b>CAT5/5e/6</b>	Category 5/5e/6 Cable
<b>CSMA/CD</b>	Carrier Sense Multiple Access with Collision Detection
<b>IEEE802.3at</b>	IEEE standard for Power Over Ethernet Plus
<b>IEEE802.3af</b>	IEEE standard for Power Over Ethernet
<b>IGMP</b>	Internet Group Management Protocol
<b>IP</b>	Internet Protocol
<b>IP30/IP31/IP67</b>	Ingress Protection or International Protection rating 30 / 31 / 67
<b>LLDP</b>	Link Layer Discovery Protocol
<b>PD</b>	Powered Device
<b>PI</b>	Power Interface
<b>PoE</b>	Power Over Ethernet
<b>PoE-Plus</b>	Power Over Ethernet Plus
<b>PSE</b>	Power Sourcing Equipment
<b>RMON</b>	Remote Network Monitoring
<b>RSTP</b>	Rapid Spanning Tree Protocol
<b>SMTP</b>	Simple Mail Transfer Protocol
<b>SNMP</b>	Simple Network Management Protocol
<b>STP</b>	Shielded Twisted Pair
<b>UPS</b>	Uninterruptible Power Supply
<b>UTP</b>	Unshielded Twisted Pair
<b>VLAN</b>	Virtual Local Area Network
<b>VoIP</b>	Voice Over IP
<b>VPSE</b>	The voltage at the PSE PI measured between any conductor of one power pair and any conductor of the other power pair

- All product specifications are subject to change without further notice.
- Before applying to critical projects, please contact Korenix headquarter for up-to-date product specifications' consultancy.